

企业简介 COMPANY PROFILES

宁波市甬热机械有限公司创立于2006年，已有9年塑料辅机专业制造经验。本着“品质为本 精益求精”的经营宗旨，一步一个脚印，严把产品品质关，同时不断加大新产品的研发力度，努力开拓创新。9年来，凭借良好的企业信用、先进的生产设备、严谨科学的管理和成熟的制造经验，产品在质量、价格、服务和实用性等方面，都赢得了广大顾客的信赖。产品远销非洲、东南亚各国，深受广大用户的好评。

我们的主要产品有塑料干燥机、塑料粉碎机、吸料机、塑料混色机、冷水机、模温机、机边回收机等十多个系列，近两百种规格型号的塑料周边设备。

Ningbo Yongre Machinery co, LTD was found in 2006, has 9 yeas of professional experience in manufacturing plastic auxiliary. quality-based excellence"business purpose, step by step, strict product quality and customs, while increasing new product development efforts to develop innovation. 9yeas, with good credit, advanced production equipment, scientific management and sophisticated manufacturing experence, product quality, price, service and availability, etc, have won the trust of customers. Products are exported to Africa, Southeast Asia, the majortiy of users. Our main products are plastic drying machine, plastic crusher, suction feeder, plastic color mixer, cold water machine, die temperature machine, machine side recycling machine and so on more than ten series, nearly two hundred standard models of plastic peripherals.



合作方式 COOPERATION

力销全球，尽显完美品质有实力才值得信赖！

一、产品销售

以“建一流平台、供一流服务、创一流效益”的经营宗旨。

以“建设中国塑料机械产业最具影响力的知名度,打造全品类、全球化、全方位,全天候永不谢幕的在线服务”。

二、战略合作

以“共享价值、利益共享”为交易准则。

ZY-干燥机 ZY-Plastic Drier



ZY-干燥机/ZY-Plastic Drier

用途与特点

- ◆ 采用均匀分散热风之高性能扩散装置，保证物料干燥温度均匀，增强干燥效率。
- ◆ 料桶内零件一律采用不锈钢制。
- ◆ 料桶与底部分离，清料方便，换料迅速，确保原料不受污染。
- ◆ 采用比例式偏差指示温控器和自制冷风机，温度控制精确，使用寿命延长。

Application&Features

- ◆ Apply high performance diffusing device for evenly dispersing hot air, keep even drying temperature for, increase the drying efficiency.
- ◆ All parts in the material barrel are made of stainless steel.
- ◆ The material barrel is separated with the bottom with convenient and fast material removing and replacing, protect raw material from pollution.
- ◆ Apply proportion type difference indicating temperature controller and the cooling air blower, assure precise temperature control and extend the serving life.

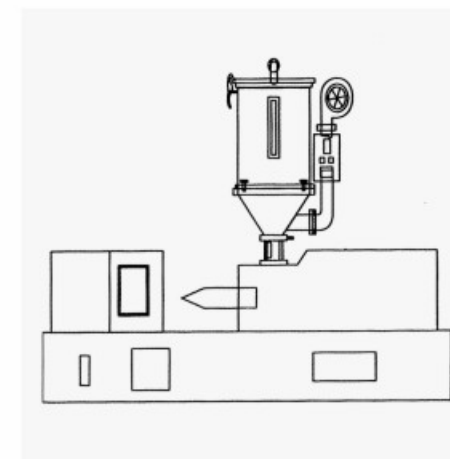

型号 Model	装料量 Feed the capacity(kg)	电机功率/Motor power(kw)		外形尺寸 Appearance size(mm)	重量 Weight(kg)
		电热/Electric heating(kw)	电机/Motor(kw)		
SHD1000E	12	1.8	50	620x400x820	22
SHD800E	25	3	120	760x500x1040	34
SHD600E	50	4.5	180	870x540x1210	45
SHD400E	75	5.5	180	940x600x1310	56
SHD300E	100	6	220	1020x730x1410	68
SHD200E	150	7.5	300	1100x770x1760	90
SHD150E	200	10	350	1200x850x1830	110
SHD100E	300	15	750	1420x1000x1880	150
SHD75E	400	15	750	1480x1060x2000	170
SHD50E	600	20	1100	1580x1160x2380	280
SHD25E	800	30	2200	1800x1280x2480	360
SHD12E	1000	30	2200	2000x1400x2480	500



ZY-B 机边机/ZY-B Machine Machine

用途与特点

- ◆ 中速设计, 可回收料支和不良品。
- ◆ 可视旋风分离器 and 可视比例底座, 回收过程一目了然。
- ◆ 边料和不良品及时回收利用, 提高经济效益。

Application&Features

- ◆ Medium-speed design, recycling materials and defective products support.
- ◆ The proportion of visual and visual cyclone base, recovery process at a glance.
- ◆ Real-time edge material and recycling of defective products increase economic efficiency.

型号 Model		低速机边粉碎机 Low-Speed Granulator			
		ZY-1820	ZY-1830	ZY-20235	ZY-2040
电机功率 Power	kw	1.1	1.5	3.0	3.0
主轴转速 Rotor Speed	rpm	150	150	150	150
转动刀 Rotating Blades	pcs	21	30	36	42
固定刀 Fixed Blades	pcs	2	2	4	4
筛网孔径 Screen Diameter	mm	Φ6	Φ6	Φ6	Φ6
粉碎室尺寸 Cutting Chamber Size	mm	270×200	270×300	295×350	295×400
粉碎能力 Output	kg/h	30~60	50~80	80~120	100~150
粉碎时噪音 Noise	dB(a)	80~85	80~85	80~85	80~85
重量 Weight	kg	150	165	200	220
外形尺寸(主机尺寸) External Size					
L	mm	790	880	1100	1190
W	mm	480	480	500	500
H	mm	1350	1350	1350	1350



ZY 机边机/ZY Machine Machine

用途与特点

- ◆ 双层进料斗, 有效降低噪音。
- ◆ 进料门内层为不锈钢, 使回收料不受污染。
- ◆ 大进料嘴口, 使料支待物料进入更顺畅。
- ◆ 中速设计, 可回收料支和不良品。
- ◆ 边料和不良品及时回收利用, 提高经济效益。
- ◆ 可视旋风分离器 and 可视比例底座, 回收过程一目了然。

Application&Features

- ◆ Double into the hopper, to reduce noise.
- ◆ Into the inner layer of stainless steel hopper, the recycling material is not contaminated.
- ◆ Mouth large feed port, make the material more smoothly into the branch to be material.
- ◆ Medium-speed design recycling materials and defective products support.
- ◆ Real-time edge material and recycling of defective products increase economic efficiency.
- ◆ The proportion of visual and visual cyclone base, recovery process at a glance.

型号 Model	主机功率 (kw)	回收能力 (g/10s)	电机功率 (w)	送料方式	入料口 (mm)	外形尺寸 (mm)	重量 (kg)
ZY 180D	1.1	150	200	风车	180x190	650x620x1150	125
ZY 240D	1.5	200	550	风车	240x210	710x680x1220	170
ZY 300D	2.2	300	550	风车	300x240	800x820x1430	250

PC强力粉碎机/PC Powerful crusher



用途与特点

- ◆ 全机采用高硬度钢模板, 坚固耐用。
- ◆ 转轴采用特殊材料加工制成, 不易变形。
- ◆ 刀具可独立调整, 可多次更磨反复使用。
- ◆ 入料斗, 刀具, 过滤网都可分解, 易拆装, 易清洗。
- ◆ 电机装有保护, 和安全开关, 保障安全。
- ◆ 出料网采用圆锥孔工艺制作, 大大提高工作效率。

Application&Features

- ◆ The whole machine adopts high hardness steel template, and I solid and, du rable.
- ◆ Shaft made of special material Processing, not easily deformed.
- ◆ Cutter can be adjusted independently. and can be sharpened with repeated use.
- ◆ Feeding hopper, cutter and filter can be separated with easy disassembling and cleaning.
- ◆ Motor is installed with overload Protection and safe switches for assuring safety.
- ◆ Discharging hole technology of cone production network, greatly enhancing efficiency.

型号 Model	破碎室口 Grinding chamber(mm)	破碎能力 Grinding capacity(kg/h)	电机功率 Motor power(kw)	定刀数 Qty of stationary blade	动刀数 Qty of rotary blade	机械尺寸 Appearance size(mm)	重量 Weight(kg)
PC180	160x180	100~150	1.5/2.2	2	9	630x520x950	140
PC230	200x230	150~200	4.0	2	6	900x640x1050	250
PC300	230x300	200~250	5.5	2	9	1030x750x1200	380
PC400	245x400	300~450	7.5	2	12	1100x860x1330	550
PC500	300x500	100~800	11	2	15	1300x1020x1520	700
PC600	335x600	450~900	15	4	18	1450x1155x1700	950
PC800	500x800	650~1300	22/37	4	24	1850x1410x2130	1700
PC1000	610x1000	750~1500	37/55	4	30	1950x1580x2500	2800

ZY-300G微电脑全自动吸料机 ZY-300G Micro Computer Fully Automatic Material Sucking Machine

用途与特点

- ◆采用高速整流马达，体积小，重量轻，吸力强，安装方便。
- ◆缺料自动报警。
- ◆微电脑控制，操作简便。
- ◆设有缺料复位开关，可在地面操作，灵活方便。
- ◆桶体采用不锈钢，保证原料不受污染，坚固耐用。

Application&Features

- ◆Apply high speed rectifying motor with small size,light weight, powerful sucking force and convenient installation.
- ◆Automatically alarm under material shortage.
- ◆Control with micro computer, convenient operation.
- ◆Set material shortage reset switch,operate on the floor, flexible and convenient.
- ◆The barrel body is made of stainless steel,solid and durable,protect raw material from pollution.



ZY-700G微电脑全自动吸料机 ZY-700G Micro Computer Fully Automatic Material Sucking Machine

用途与特点

- ◆采用高速整流马达，体积小，重量轻，吸力强。
- ◆分体式设计，容易操作和清理。
- ◆缺料和满料自动报警。
- ◆不锈钢料桶，坚固耐用。

Application&Features

- ◆Rectifier with high-speed motor, small size,light weight,strong suction.
- ◆Split design,easy operation and cleaning.
- ◆Expected shortage of material and full automatic alarm.
- ◆Stainless steel barrel,durable.



ZY-800G分体式微电脑全自动吸料机 ZY-Divided Micro Computer Fully Automatic Material Sucking Machine

用途与特点

- ◆全自动电脑控制，操作简便。
- ◆过载，缺料自动报警。
- ◆采用三相高压，静音风机，结构紧凑，马力强劲。
- ◆不锈钢料桶，坚固耐用。

Application&Features

- ◆Fully automatic computer control, simple operation.
- ◆Automatically alarm under overload and material shortage.
- ◆Apply 3-phase high voltage,silent fan,compact structure,high power.
- ◆Stainless steel material barrel,solid and durable.



ZY-900G分体式微电脑全自动吸料机 ZY-Divided Micro Computer Fully Automatic Material Sucking Machine

用途与特点

- ◆全自动电脑控制，操作简便。
- ◆过载，缺料自动报警。
- ◆采用三相高压，静音风机，结构紧凑，马力强劲。
- ◆不锈钢料桶，坚固耐用。
- ◆具有逆转自动清除粉尘功能。

Application&Features

- ◆Fully automatic computer control, simple operation.
- ◆Automatically alarm under overload and material shortage.
- ◆Apply 3-phase high voltage,silent fan,compact structure,high power.
- ◆Stainless steel material barrel,solid and durable.
- ◆With the function of automatically removing dust.



型号 Model		ZY-300G	ZY-700G	ZY-800G	ZY-800G	ZY-900G
马达 Motor	型式 Type	碳刷式 Carbon Brush	碳刷式 Carbon Brush	感应式 Induction	感应式 Induction	感应式 Induction
	规格 Specification	1100w1Φ	1100w1Φ	1100w3Φ	1500w3Φ	2200w3Φ
输送能力(kg/hr)Transmission Capacity		350	350	450	550	650
静风压 Static Pressure		150mmAp	150mmAp	1450mmAp	2000mmAp	2200mmAp
滤清器 Filter		Φ185*90H	Φ185*115H	Φ188*115H	Φ188*115H	Φ188*115H
储料桶容量 (L) Storage Tank Capacity		7.5	7.5	7.5	7.5	7.5
输料管内径 Conveying Pipe Diameter		Φ38	Φ38	Φ38	Φ38	Φ38
外形尺寸 External Size	主体 Subject	500*400*600	480*310*430	680*370*500	680*370*500	700*370*500
	储料筒 Storage Barrel		430*440*295	430*440*295	430*440*295	430*440*295
重量 (kg) Weight	主体 Subject	13.5	15.5	35	35	45
	储料筒 Storage Barrel		5	6	5	6

ZY-拌料机 ZY-Mix Machine



ZY-拌料机/ZY-Mix Machine

用途与特点

- 浆叶采用特殊工艺制作，使每桶料的均匀混和时间比同类产品快1倍。
- 桶体采用圆锥形桶底，配合仿形浆叶，短时间完成均匀拌料，效率高。
- 搅拌浆叶与桶体均属不锈钢制造，且浆叶可摘下保养，使寿命加长。
- 仿形密合式搅拌，容量大，操作方便。
- 电机直接驱动，减少功率损耗，不打滑。
- 混合时间可按需要设定，定时停机。

Application&Features

- Blades produced using special technology to make a barrel of uniform material mixing between 1 times faster than similar products.
- The barrel body applies taper bosom with profile modeling Blades, instantly and evenly mix materials with high efficiency.
- Mixing Blades and the barrel body are made of stainless steel, the Blades can be removed for maintenance, thus prolonging the service life.
- Profile modeling closed mixing, high capacity, convenient operation.
- Directly drive with motor drop power consumption without sliding.
- The mixing time is set according to actual requirement, timing stop.

型号 Model	混合量 Mixing capacity(kg)	电机功率 Motor power(kw)	转速 Rotary speed(r/min)	外形尺寸 Appearance size(mm)	重量 Weight(kg)
ZY25kg	25	0.75	80	720x670x900	90
ZY50kg	50	1.5	80	850x810x1070	120
ZY100kg	100	3	80	1020x980x1360	170
ZY150kg	150	4	68	1150x1050x1400	230
ZY200kg	200	5.5	68	1300x1180x1500	320
ZY300kg	300	7.5	58	1450x1350x1650	380

ZY-水冷式冷水机/ZY-Water chiller

- ◆ **高品质压缩机**
作为冷水机的核心，屹立冷水机挑选欧美日全新进口优质原装压缩机，内置安全保护，低噪音，省电耐用。
- ◆ **水箱式蒸发器**
不锈钢厚质水箱式蒸发器，内置自动补水等装置，省去工程安装中的膨胀水箱，方便安装保养，并适用于大温差小流量等特殊场合。
- ◆ **水冷式冷凝器**
日本神户最新高效外螺纹铜管制作，散热量大体积小。运用最新CAD、CAM设计加工技术，配合CNC加工中心制作完成，结构紧凑，可靠性高，外形美观，高效节能。
- ◆ **机组配置个**
配置精密电子温度控制器。精确控制水温于5-20°C以内。内置压缩机超负载保护器。循环水泵超负载掣，系统高低压力异常保护器，高效进口干燥过滤器及膨胀阀，维修手阀接口等装置，确保了机器可靠安全运行，方便了保养维修。
- ◆ **可选择的水泵配置**
根据用户工程设计要求配备进口高效节能水泵，使屹立冷水机安装使用快捷方便。
- ◆ **多功能操作面板**
操作面板装有电流表，控制系统保险，压缩机开关按钮，水泵开关按钮，电子温控器，各项安全保护故障灯，机组启动运转指示灯，操作简单，使用方便。

◆ **High quality compressor**
As a heart of mater-cooling machine,obote choose the original compressor from european and USA with safety production inside,low noise,energy saving and long life.

◆ **Evaporator as water rand style**
Thick stainless steel evaporator with automatic water supplying device,the awell water tank during the installation will be saved,easy to install and maintain,and also suitable for the case of big temperature deviations,small flow.

◆ **Water-cooling condenser**
Made from UKB latest outside threaded cooper thbe,good heat dissipation use the latest CAD, CAM R&D technic,made from CNC which has a feature of compact structure,energysaving,good shape and reliable performance.

◆ **Machine Configuration**
Equiped with exact electric temperature controller which control the water temperature between 5-20°C.inside which there is a overlo ad protector, high pressure abnormal protector, imported dry filter and swell valve for stable running and easy repairing and maintaince.

◆ **Pump configuration for option**
Imported high efficiency pump is available according to customer's requirement.

◆ **Multi function operation panel**
There are current monitor, compressor on-off swich,pump on-off swich,elect ric temperature controller, safety runing alert light on the panel.

技术参数/SPECIFICATIONS

型号 Model	UNIT	ZY-04AC	ZY-05AC	ZY-08AC	ZY-10AC	ZY-12AC	ZY-15AC	ZY-20AC	ZY-25AC	ZY-30AC	ZY-40AC	
制冷量 Refrigeration capacity	kw	11.9	15	23.8	30.5	34.3	45	61	69	92	112	
	kcal/h	10234	12900	20468	26230	29498	38700	52460	59340	79120	104920	
压缩机 Compressor	输入功率Input power	kw	3	4.5	3x2	4.5x2	10	4.5x3	9x2	10x2	9x3	9x4
	额定功率Rated power	hp	4	5	4x2	5x2	12	5x3	10x2	12x2	10x3	20x2
蒸发器 Evaporator	类型 Type	盘管式蒸发器 Pipe coil eveprator					壳管式蒸发器 Shell eveprator					
	水径管口 Pipe power	Inch	1	1	2	2	2	2-1/2	2-1/2	2-1/2	3	
冷冻媒体 Refrigerant	类型 Type	R22										
	填充量 Quantity	kg	2	2.5	4	5	5	7.5	10	11	12	18
风冷冷凝器 Air cooled condenser	类型 Type	翅片式冷凝器 Finned condenser										
	风机功率 Fan power	kw	0.15x2	0.2x2	0.3x2	0.4x2	0.5x2	0.8x2	0.5x4	0.5x4	0.4x6	0.4x8
冷却水量 Chill water liter	L/min	65	70	100	110	150	170	230	270	330	480	
水箱容量 Water tank capacity liter	liter	50	50	70	70	125	125	140	140	150	180	
水泵 Pump	功率 Power	kw	0.75	0.75	1.5	1.5	2.2	2.2	4	4	4	4
	流量 Flow rate	hp	1	1	2	2	3	3	5	5	5	5
管径 Pipe	冷水出口 Cooling water out let	Inch	1/2x4	1/2x4	2	2	2	2	2-1/2	2-1/2	2-1/2	3
接口尺寸 Connection size	冷水回口 Cooling water in let	Inch	1/2x4	1/2x4	2	2	2	2	2-1/2	2-1/2	2-1/2	3
外形尺寸 Dimensions (LxWxH)	风冷 Air cooled	cm	126x60x101		138x80x135		190x100x140 200x120x155 200x135x155 220x135x155 320x148x210					
	水冷 Water cooled	cm	103x55x94		132x72x127		154x85x130 210x85x151 210x35x151 224x88x151 250x85x150					

ZY-水冷式冷水机/ZY-Water chiller



技术参数/SPECIFICATIONS

型号 Model	UNIT	ZY-04AC	ZY-05AC	ZY-08AC	ZY-10AC	ZY-12AC	ZY-15AC	ZY-20AC	ZY-25AC	ZY-30AC	ZY-40AC	
制冷量 Refrigeration capacity	kw	11.9	15	23.8	30.5	34.3	45	61	69	92	112	
	kcal/h	10234	12900	20468	26230	29498	38700	52460	59340	79120	104920	
压缩机 Compressor	输入功率Input power	kw	3	4.5	3x2	4.5x2	10	4.5x3	9x2	10x2	9x3	9x4
	额定功率Rated power	hp	4	5	4x2	5x2	12	5x3	10x2	12x2	10x3	20x2
蒸发器 Evaporator	类型 Type	盘管式蒸发器 Pipe coil eveprator					壳管式蒸发器 Shell eveprator					
	水径管口 Pipe power	Inch	1	1	2	2	2	2-1/2	2-1/2	2-1/2	3	
冷冻媒体 Refrigerant	类型 Type	R22										
	填充量 Quantity	kg	2	2.5	4	5	5	7.5	10	11	12	18
风冷冷凝器 Air cooled condenser	类型 Type	翅片式冷凝器 Finned condenser										
	风机功率 Fan power	kw	0.15x2	0.2x2	0.3x2	0.4x2	0.5x2	0.8x2	0.5x4	0.5x4	0.4x6	0.4x8
冷却水量 Chill water liter	L/min	65	70	100	110	150	170	230	270	330	480	
水箱容量 Water tank capacity liter	liter	50	50	70	70	125	125	140	140	150	180	
水泵 Pump	功率 Power	kw	0.75	0.75	1.5	1.5	2.2	2.2	4	4	4	4
	流量 Flow rate	hp	1	1	2	2	3	3	5	5	5	5
管径 Pipe	冷水出口 Cooling water out let	Inch	1/2x4	1/2x4	2	2	2	2	2-1/2	2-1/2	2-1/2	3
接口尺寸 Connection size	冷水回口 Cooling water in let	Inch	1/2x4	1/2x4	2	2	2	2	2-1/2	2-1/2	2-1/2	3
外形尺寸 Dimensions (LxWxH)	风冷 Air cooled	cm	126x60x101		138x80x135		190x100x140 200x120x155 200x135x155 220x135x155 320x148x210					
	水冷 Water cooled	cm	103x55x94		132x72x127		154x85x130 210x85x151 210x35x151 224x88x151 250x85x150					

ZY-水式/油式模温机 ZY-Water/Oil MTC



ZY-水式/油式模温机/ZR-Water/Oil MTC

用途与特点

- 自动模控机采用最先进电脑程序控制原理，配合精密电子温度实行两级温度控制，使温度的精密达到 $\pm 0.5^{\circ}\text{C}$ 。
- 采用油或水作为热介质，安全可靠。
- 两组发热管,使油缸过载之自动警示系统，回路自动切断，确保安全。
- 采用不锈钢容桶，耐腐蚀、寿命长。
- 采用电脑精确温度控制及独立冷却器，使温度更加稳定。

• Automatic molding tool temperature control machine adopts the advanced computer, and match with precise electronic thememter Practice two class tempe ratu re control, Make temperatur's accurate degree attain $+0.5^{\circ}\text{c}$.

• Adoptiol or water conduct and actions hot spread to lie the quality, safety dependable.

• Two sets have favr the line, and make first temperature is average stability, save time,province electrcityo Had to have an oil and exceed the temperature, water to pump to carry its automatic police toshow the system, four roads automatically cat dff, insure the safety.

• Adopt stainless steel permits the bucket, and bear to decay,life span is long.

• Adopt import comprter controller and independent water cooler, and make the temperature more stable.

水式模温机/WATER MTC 技术参数/SPECIFICATIONS

型号 Model	ZY-6KM	ZY-9KM	ZY-12KM	ZY-18KM	ZY-24KM	ZY-36KM	ZY-48KM
传热媒体 Heat-transfer Medium	水 Clena Water						
加热能量 Heating Capacity	120°C						
冷却方式 Cooling Method	直接冷却 Direct Cooling						
功率 Power(kw)	0.37	0.75	0.75	1.5	1.5	3.75	3.75
压力 Pressure Pump(kg/cm)	2.5	4	4	4	4	4	4
流量 Flow Volume(l/min)	35	45	45	80	80	380	380
加热功率 Heating Method(kw)	6	9	12	18	24	36	48
电源 Power Supply	三相 380v/460v 50Hz/60Hz						
冷却水管径 Cooling-water pipe size	1/2"	1/2"	1/2"	1/2"	1/2"	1/2"	1/2"
热媒管径 Heat-transfer pipe size	2xΦ10	4xΦ10	4xΦ10	6xΦ10	6xΦ10	6xΦ10	6xΦ10
油箱容量 Fuel tank capacity(l)	/	/	/	/	/	/	/
外形尺寸 External Di mensionsl xwxh	760x300x640	760x300x640	760x300x640	890x380x690	890x380x690	1050x550x850	1050x550x850
重量 Weight(kg)	43	49	52	90	90	110	115

油式模温机/OIL TYPE MTC 技术参数/SPECIFICATIONS

型号 Model	ZY-6KM	ZY-9KM	ZY-12KM	ZY-18KM	ZY-24KM	ZY-36KM	ZY-48KM
传热媒体 Heat-transfer Medium	传热油 Heal Transfer Oil						
加热能量 Heating Capacity	180°C						
冷却方式 Cooling Method	间接冷却 Indirect Cooling						
功率 Power(kw)	0.37	0.75	0.75	1.5	1.5	3.75	3.75
压力 Pressure Pump(kg/cm)	2.5	4	4	4	4	4	4
流量 Flow Volume(l/min)	35	45	45	80	80	380	380
加热功率 Heating Method(kw)	6	9	12	18	24	36	48
电源 Power Supply	三相 380v/460v 50Hz/60Hz						
冷却水管径 Cooling-water pipe size	1/2"	1/2"	1/2"	1/2"	1/2"	1/2"	1/2"
热媒管径 Heat-transfer pipe size	2x3/8	4x3/8	4x3/8	6x3/8	6x3/8	1x1.5'	1x1.5'
油箱容量 Fuel tank capacity(l)	10	13	16	24	24	38	38
外形尺寸 External Di mensionsl xwxh	760x300x640	760x300x640	760x300x640	890x380x690	890x380x690	1050x550x850	1050x550x850
重量 Weight(kg)	47	53	57	95	98	120	125